

RUPERT
NEVE
DESIGNS



Portico[™] 5014

STEREO FIELD EDITOR

USER GUIDE

Serial No:

<input type="text"/>	<input type="text"/>	<input type="text"/>	<input type="text"/>	<input type="text"/>	<input type="text"/>	<input type="text"/>
----------------------	----------------------	----------------------	----------------------	----------------------	----------------------	----------------------

IMPORTANT

For your convenience, write your serial number on the box above and keep this guide in a safe place. The number can be found on the bottom of the product and also on the packaging materials.

This number must be quoted in all communications in order to obtain technical support and spare parts from either the factory or your dealer.

Thank you for your purchase of the Portico™ 5014 Stereo Field Editor. Everyone at Rupert Neve Designs hopes you enjoy using this tool as much as we have enjoyed designing and building it. Please take note of the following list of safety concerns and power requirements before the use of this or any Portico™ Series product.

SAFETY

It's Usual to provide a list of “do’s and don’ts” under this heading but mostly these amount to common sense issues. However, here are some reminders:

- The Portico™ 5014 dissipates about 12 watts, which means it will get warm in use. The heat generated is radiated through the casework and by convection through the ventilation holes on the sides. Therefore, the holes should not be covered or blocked. Portico™ modules may be stacked horizontally on a desktop or mounted vertically in a rack without heat problems. The anti-slip feet may be removed while used in a rack, but should be retained for desktop use. To avoid overheating Portico™ modules should not be stacked immediately above or adjacent to other equipment that gets hot. Also bear in mind that other equipment may radiate strong hum fields, which could spoil the performance of your Portico™ module.
- Don't operate your Portico™ module in or around water! Electronic equipment and liquids are not good friends. If any liquid is spilled such as soda, coffee, alcoholic or other drink, the sugars and acids will have a very detrimental effect. Sugar crystals act like little rectifiers and can produce noise (crackles, etc.). SWITCH OFF IMMEDIATELY! Once current starts to flow, the mixture can get very hot and harden like burnt toffee, causing permanent and costly damage. Please contact support as soon as possible at support@rupertneve.com for resolution.
- Don't operate a Portico™ in the rain! If it gets wet, and you suspect that good clean water may have gotten in, immediately unplug the unit, and remove it from the source of water. Take the cover off by removing the knobs and the two back-most screws on both sides. The cover and front panel will now slide forward and free from the unit. Gently wipe off any water that's visible with a soft cloth. Water may have percolated under the Printed Circuit Board and be hidden between it and the bottom cover. A hair drier can be used with care to blow and dry out any residual moisture. Leave the unit for a few hours to completely dry out. If the moisture was due to CLEAN water, your Portico should be up and running with no further problems.
- Don't be tempted to operate a Portico™ with the cover removed. The cover provides magnetic screening from hum and R.F. stray fields.

POWER REQUIREMENTS

Every Portico™5014 module is fitted internally with a fully shielded and sealed DC to DC converter that provides the pristine isolated and filtered balanced DC voltages required for the discrete amplifiers. The meticulous audio quality of your Portico™ is protected by the internal converter that screens and protects the internal circuits from outside interference, allowing Portico™ modules to be fed from any external DC supply between 9 and 18 volts that is reasonably “clean.” The Portico™ DC input is protected from reverse polarity. The DC power unit normally provided with the 5014 is a high quality, robust, and very reliable switched mode supply that will work from almost any of the very wide range of mains supply voltages and frequencies that are found world-wide. Other than meeting the requirement for high quality and the regulatory specs for this class of equipment, there are no special constraints for the Portico™ power units.

When feeding multiple units, obviously they should be capable of providing enough current for the number of Portico™ modules in use.

The great advantage of this system is that there are no common DC supply rails that could share signals with other modules and potentially cause crosstalk.

Portico™ power units leave the factory with standard US plugs. If required, any suitable connecting cord may be substituted. Avoid using a mains power outlet that is on the same circuit as air conditioning or other equipment that regularly switches on and off. It is common sense to unplug your Portico™ power unit during a thunder storm or if it will be unused for a long period.

Portico™ modules can alternately be powered from a 12-volt battery, in which case the supplied AC power unit is not needed. When using a 12-volt battery, choose one that has enough capacity to power your Portico™ 5014 - or your complete assembly of Portico™ modules - for the expected duration of your session.

The Rupert Neve Designs 5014 Stereo Field Editor

The Stereo Field Editor is a new tool that draws out and enables the engineer to make full use of the embedded sound field, latent in a good studio or concert hall. As its name suggests, the module depends upon connection to a pair of input channels that carry traditional Left and Right Stereo information. Sound images depend upon differences of level and phase between the two channels that are often very small indeed.

CONTROLS

Each Channel is provided with the following front panel controls:-

LINE or BUSS

An Illuminated Push-Button selects between the rear XLR (Line) and TRS (Buss) Input Sources.

PHASE

An Illuminated Push-Button inverts the phase of the input signal by 180 degrees.

LEVEL

A pair of rotary controls provide an input gain range for each channel of + 12 to - 6 dB.

WIDTH

The Width Push-Button activates the "Mono" - "Wide" knob and enables INSERT, DEPTH and EQ circuits (I.e. all the other features in the section).

— *As such, WIDTH becomes the key that enables these secondary controls.* —

"Mono" / "Wide" Knob

When the "Mono" / "Wide" knob is rotated to "WIDE", the amount of difference material present in the Left and Right inputs is differentiated, and either amplified or attenuated then mixed back into the Left and Right output circuits respectively.

Adding ambience or non-coherent reverberation to the sound field (rotating towards "WIDE") increases warmth and the apparent size of a studio or concert location. In an open air or non-reverberant situation background sounds and effects are increased. Conversely, when rotated to "mono", the stereo field is reduced.

If the LEFT and RIGHT input channels contain a high content of coherent or mono material or are actually a MONO source, there is nothing to separate. When the left and right inputs are added together and mixed back into the left and right outputs, the respective output levels are simply increased. The Left and Right output levels may increase by up to 6 dB.

If one of the INPUT channels is phase reversed, the mono content of the program can be virtually nulled out by turning the WIDTH control to the extreme counter-clockwise limit !

NOTE: If the program material is recorded in Mono format there will be no sonic difference when the WIDTH button is pressed and the "Mono" / "Wide" knob is rotated back and forth between extremes. *(This is a guaranteed way to find out if the program material is actually Stereo or Mono)*

DEPTH

Depth is operational when the WIDTH and DEPTH Push-Button are engaged. This moves the perceptual Mono image closer or further away. Used with WIDTH, the perceived ambience, room and distance of a recording stage can be controlled by introducing variable amounts of phase shift into the difference circuit.

INSERT

The INSERT Push-Button sends the difference circuit to balanced send and return TRS points on the rear panel. This enables an external Equalizer or Dynamics unit to be inserted providing further editing of the apparent Depth.

EQ IN

In addition to the INSERT circuit, a semi-parametric EQUALIZER is provided, having a frequency range of 120 to 2.4Khz, + and -15dB gain, and two "Q" settings; "High" and "Low"

METERS

8 segment LED bar-graph meters are provided for separate left and right level monitoring.

PRACTICAL USES

The first key feature of the 5014 is its width control, which enables the user to add to or reduce the width of a stereo image (wide/mono) and adjust the level of ambience inherent in the recording. For instance, a drum buss that needs to be tightened up can easily be processed with the width circuit towards mono, or a background vocal buss that is smothering a lead vocal can be opened up to let the center material breathe.

The depth control of the 5014 adjusts the spatial positioning of elements in the sound stage. A lead instrument or vocal can be placed up front in a mix and supporting instruments can be pushed back and adjust the placement of elements on the sound stage. In many cases, a center panned vocalist can be placed forward in a mix or virtually eliminated without adversely affecting the music matrix.

The difference channel insert and EQ creates new opportunities to manipulate stereo signals. In mastering use, lead vocals can be brought up or down in a mix, excessively sibilant overheads can be controlled, and mixes that were once beyond repair can be saved. As a creative tool the difference channel insert on the 5014 are only limited by the users creativity.

DISSERTATION ON STEREO PROCESSING

WIDTH

It is possible to insert filters, extra reverb, compressors, expanders etc. into the DIFFERENCE path and get some amazing sounds. PHASE differences can also be enhanced.

Things of this type are essential, in my view to enhance digital recordings so they "sound" better. One of the failings of DIGITAL is that it does not give you enough DIFFERENCE information even to localize and place ordinary stereo sources. We can make them appear to do a great deal more than they do.

MONO

Where there is no difference between the two channels, there is nothing for the WIDTH control to work with. When Left and Right channels are combined at the 5014 output, the image produced is apparently 6 dB greater due to adding two identical (or near identical) levels from the two loudspeakers acoustically.

When the two microphones in the studio are receiving two signals that are quite different in content, due to non-phase coherent reverberation or placement of instruments, our differentiating circuit amplifies - or, in some cases, reduces - those differences. Adding them back into the Left and Right outputs now brings in more of the "big picture".

The way in which the difference signals are combined into the output circuits is governed by the DEPTH control and gives an even greater perspective to the sound picture.

Differentiating stereo signals in this way, whether from microphones or from already recorded sources, is similar to the AB - MS coding traditionally used extensively in the recording studio.

It's important to realize that there is a big difference between stereo and panned mono:- Identical signals coming from 2 speakers produce an exact virtual image between the speakers. Non-identical signals don't although the signals may be similar. Soloists are often captured on a single mono microphone and panned center. This is how it is possible to reverse the phase of one of the input channels and literally null out a soloist!

STEREO

If the soloist in the Studio moves, the relative signals change in amplitude and phase causing the image to move also. A Stereo signal also contains ambience information which locates the soloist relative to his surroundings. With panned Mono, the ambience is fixed by the simple ratio of direct to ambient sound produced by the microphone/soloist positions. Panning cannot change this relationship.

Try this to establish whether a signal is real Stereo or Panned Mono: Set up your recording on a pair of monitor speakers and listen to see if there is a "Sweet Spot" for the soloist either at the Centre or at a definite point off Centre. During the mix, the soloist is likely to have been positioned by the Pan Pot.

As you move between the two speakers you will hear this "Sweet Spot" where the two signals have added coherently to produce the familiar forward image. If the soloist has been recorded on a genuine Stereo pair, there will be no such obvious "Sweet Spot" but he/she will retain the perspective produced by their Studio position relative to the Stereo Microphone pair.

POWER REQUIREMENTS

Voltage Range

9 to 18 Volts DC, 12 Watts

Current Consumption:

@ 9VDC = 1.25 A typical
 @12VDC = 1000 mA typical
 @15VDC = 780 mA typical
 @18VDC = 643 mA typical

Connector: 5.5mm X 2.5mm DC jack, Center Positive

5014 Stereo Field Editor - Front Panel

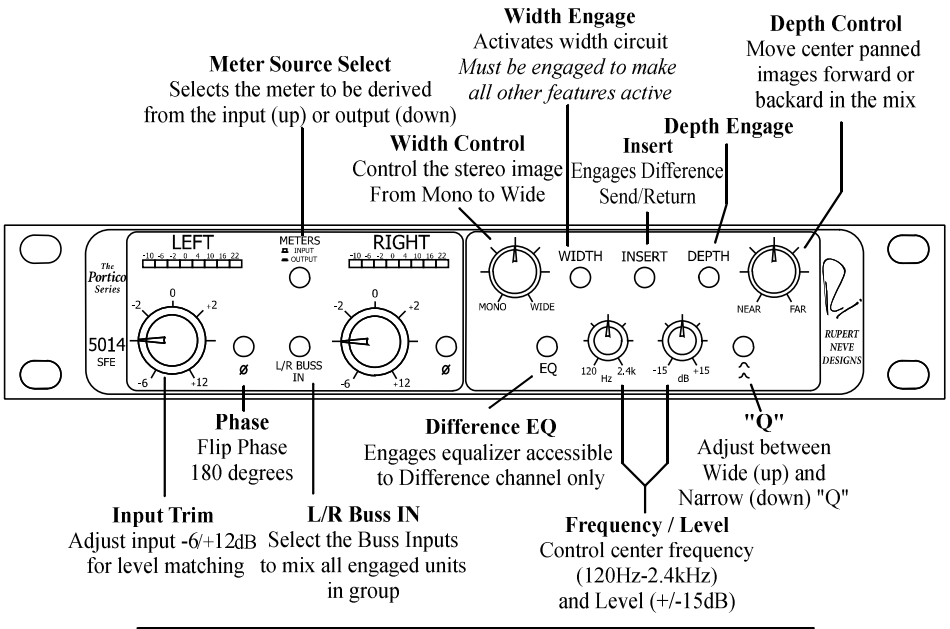

5014 Stereo Field Editor - Back Panel

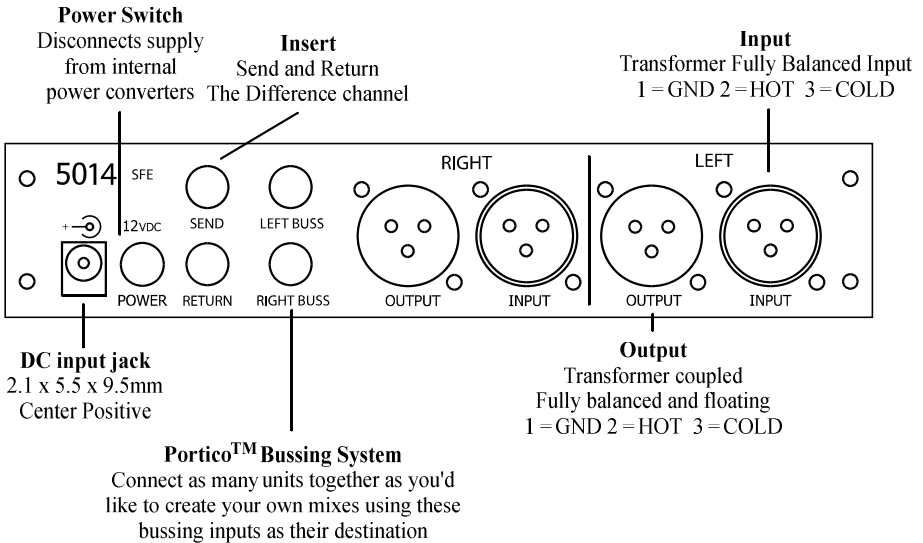

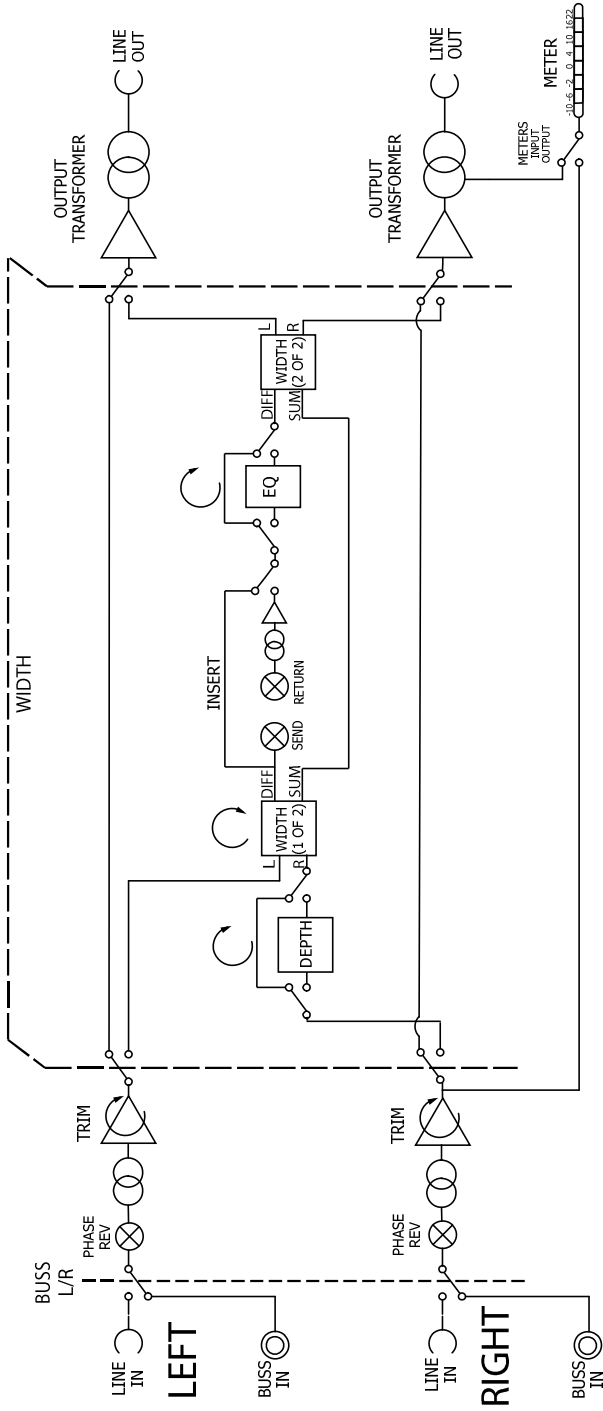

Portico 5014-Stereo Field Editor

GAIN:	Each channel independently variable from -6 dB to +12 dB.	
MAXIMUM OUTPUT LEVEL:	Balanced and Floating Transformer Output +25 dBu.	
INPUTS (XLR):	Input Impedance: >10K Ohms Transformer balanced and Floating.	
WIDTH:	Pressing this button engages the Width control and activates any other pushbuttons associated with it (i.e. Depth, EQ, Insert and Q).	
DEPTH:	Engages DEPTH control.	
EQ IN:	Inserts equalization into the difference channel only (post Send/Return). The internal EQ provides up to 15 dB of boost or cut and continuously variable from 120 Hz to 2.4 kHz.	
Q:	Selects either wide or narrow EQ effect.	
The Q, EQ IN, and DEPTH pushbutton will only be illuminated and activated when the WIDTH button is also engaged. Disengaging the WIDTH automatically disengages the EQ, DEPTH, and INSERT circuitry.		
METERS:	LEFT and RIGHT channel meters are simultaneously monitored via a single pushbutton toggling between both INPUT (internal post-gain trim) and OUTPUT levels.	
L/R BUSS IN:	Selects rear left and right XLR line level inputs or 1/4" Buss Input jacks to accept all Portico series Buss Outputs.	
TOTAL HARMONIC DISTORTION AND NOISE:	@ 2 kHz, +20 dBu output level, unity gain.	
	Main Output, Width bypassed:	Better than 0.0015%.
	Main Output, Width engaged:	Better than 0.0015%.
NOISE:	Measured at Main Output, un-weighted, 22Hz-22 kHz, Terminated 40 Ohms.	
	With Gain at Unity, Width disengaged:	Better than -100 dBu.
	With Gain at Unity, Width engaged:	Better than -96 dBu.
FREQUENCY RESPONSE:	Main Output, Unity Gain	@ 18 Hz, -3 dB. @ 150 kHz -3 dB.
CROSSTALK:	Measured Channel to Channel Width disengaged:	Better than -90 dB @ 16 kHz.
INSERT:	The Insert is only active within the WIDTH circuit when it is engaged. The SEND carries the Left-Right difference information only (pre-EQ). Return is half-normaled.	
TOTAL HARMONIC DISTORTION AND NOISE:	@ 2 kHz, +20 dBu output level	Better than 0.0015%.
FREQUENCY RESPONSE:	Main Output, Unity Gain	10Hz - 100 kHz, +/- 0.50 dB.
SEND	Maximum Output Level:	Balanced TRS +28 dBu. Unbalanced +22 dBu.
SEND AMPLIFIER NOISE:	Un-weighted, 22Hz-22kHz, E.I.N. (Equivalent input noise, Terminated 40 Ohms)	-100 dB
RETURN	Maximum Input Level: Transformer balanced, floating Input Impedance: >10K Ohms	+25 dBu.